



D

Wichtige Sicherheitshinweise

Die Installation Ihrer neuen Leuchte darf ausschließlich von autorisierten Fachpersonen durchgeführt werden.



www.till-hilft.de

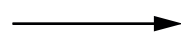

Montagehilfen



PL

Ważne wskazówki dotyczące bezpieczeństwa

Ta instalację nowej lampy mogą przeprowadzać wyłącznie autoryzowani instalatorzy



www.till-hilft.de

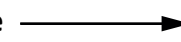

Montagehilfen



GB

Important safety instructions

The installation of your new luminaire may only be carried out by authorized specialists.



www.till-hilft.de



Montagehilfen



SK

Dôležité bezpečnostné upozornenia

Inštaláciu lampy smú vykonať výhradne autorizovaní



www.till-hilft.de

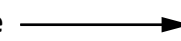

Montagehilfen



FR

signes de sécurité importantes

La L'installation votre nouveau luminaire doit uniquement être réalisée par des spécialistes autorisés



www.till-hilft.de



Montagehilfen



HU

Fontos biztonsági utmutatások

Az On Új lámpájának beszerelését kizárólag hivatalos szakember végezheti el



www.till-hilft.de



Montagehilfen



IT

Important disposizioni di sicurezza

L'installazione della il loro nuovo lampada può essere eseguita solo ed esclusivamente da personale tecnico autorizzato.



www.till-hilft.de

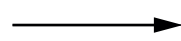

Montagehilfen



RO

Instrucțiuni de siguranță importante

Instalarea noii dumneavoastră lămpi este permisă exclusiv specialișilor autorizați



www.till-hilft.de

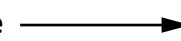

Montagehilfen



NL

Belangrijke veiligheidsaanwijzingen

De installatie van de nieuwe lamp moet worden uitgevoerd door vakbekwame personen worden uitgevoerd.



www.till-hilft.de



Montagehilfen



TR

Önemli güvenlik uyarıları

Yeni lamba montajı yetkin kişiler tarafından yapılmalıdır



www.till-hilft.de



Montagehilfen



CZ

Důležité bezpečnostní pokyny

Instalaci nových svídel smí provádět pouze kvalifikovaný elektrikář



www.till-hilft.de

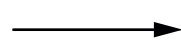

Montagehilfen



RU

важная информация по технике безопасности

Установка вашей новой лампы должна выполняться квалифицированным персоналом



www.till-hilft.de

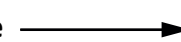

Montagehilfen



89904.330



88087.531

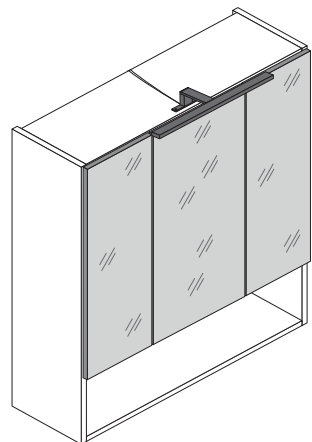

3D-Effekt

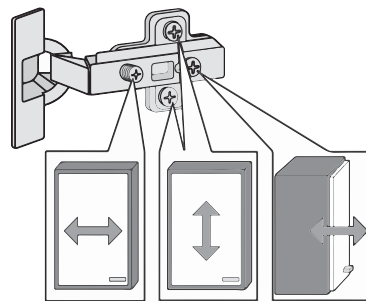
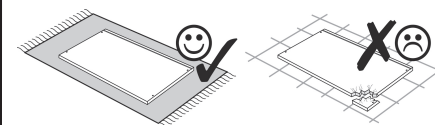
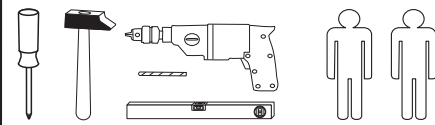
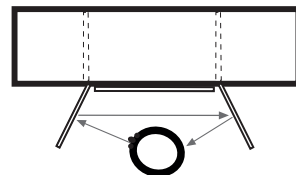

1 4 x 2802	2 4 x 2801	gedämpft 3 x 1506	ungedämpft 3 x 1507	6 x 1614
3,5 x 15 26 x 2804	8 x 30 16 x 2861	4 x 30 4 x 2812	5,8 x 55 2 x 2840	8 x 30 2 x 2842
2 x 2843	6 x 2865	Leim 1 x 2863	24 x 2819	1 x 600.00.02
3,5 x 17 20 x 2832	6 x 2552	5 x 25 4 x 2860	1 x	8mm 4 x

Colli 2

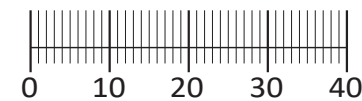
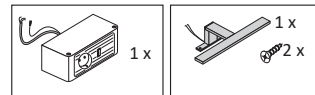

Das beigefügte Wandbefestigungsmaterial (Dübel und Schrauben) eignet sich nur für festes Mauerwerk (z.B.: Beton- oder Ziegelwände). Für andere Wandaufbauten sind eventuell Spezialdübel und andere Schrauben notwendig. Ziehen Sie gegebenenfalls eine Fachkraft zu Rate.

De begeleidende wandmontage hardware (pluggen en schroeven) is alleen geschikt voor massief metselwerk (bijvoorbeeld beton of bakstenen muren). Voor andere muur structuren zijn eventueel bijzondere ankerbouten en andere noodzakelijke. Draai indien nodig, een deskundige.

Приложенный материал для крепления к стене (дюбели и винты) пригоден только для жестких кладок (например, бетонные или кирпичные стены). Для других настенных конструкций необходимы смотря по обстоятельствам специальные дюбели и другие винты. При необходимости проконсультируйтесь у специалиста.

Le mur d'accompagnement matériel de montage (chevilles et les vis) n'est adapté que pour la maçonnerie solide (par exemple en béton ou des murs de briques). Pour les structures de mur d'autres sont peut-être spéciale boulons d'ancrage et d'autres nécessaires. Serrer le cas échéant, un expert.

Załączony materiał do mocowania do ściany (kolki rozprężne i wkręty) nadaje się tylko do ścian murowanych (np. z betonu lub cegieł). Do ścian wykonanych w innych technologiach konieczne być mogą specjalne kolki rozprężne i inne wkręty. W razie potrzeby skorzystaj z fachowej pomocy

Il muro di accompagnamento hardware di montaggio (tasselli e viti) è adatto solo per muratura piena (ad esempio calcestruzzo o muratura). Per le altre strutture murarie sono forse speciali bulloni di ancoraggio e necessari di altri. Serrare se necessario, un esperto.

The accompanying wall mounting hardware (anchors and screws) is suitable only for solid masonry (eg concrete or brick walls). For other wall structures are possibly special anchor bolts and other necessary. Tighten if necessary, an expert.

Ekteki duvara sabit montaj malzemeleri (dübel ve vidalar), sadece sağlam duvarlar için (örnek: beton veya tuğla) elverişlidir. Başka duvarlar için özel dübeller ve farklı vidalar gerekebilir. Gerekliğinde bir uzmana danışınız.

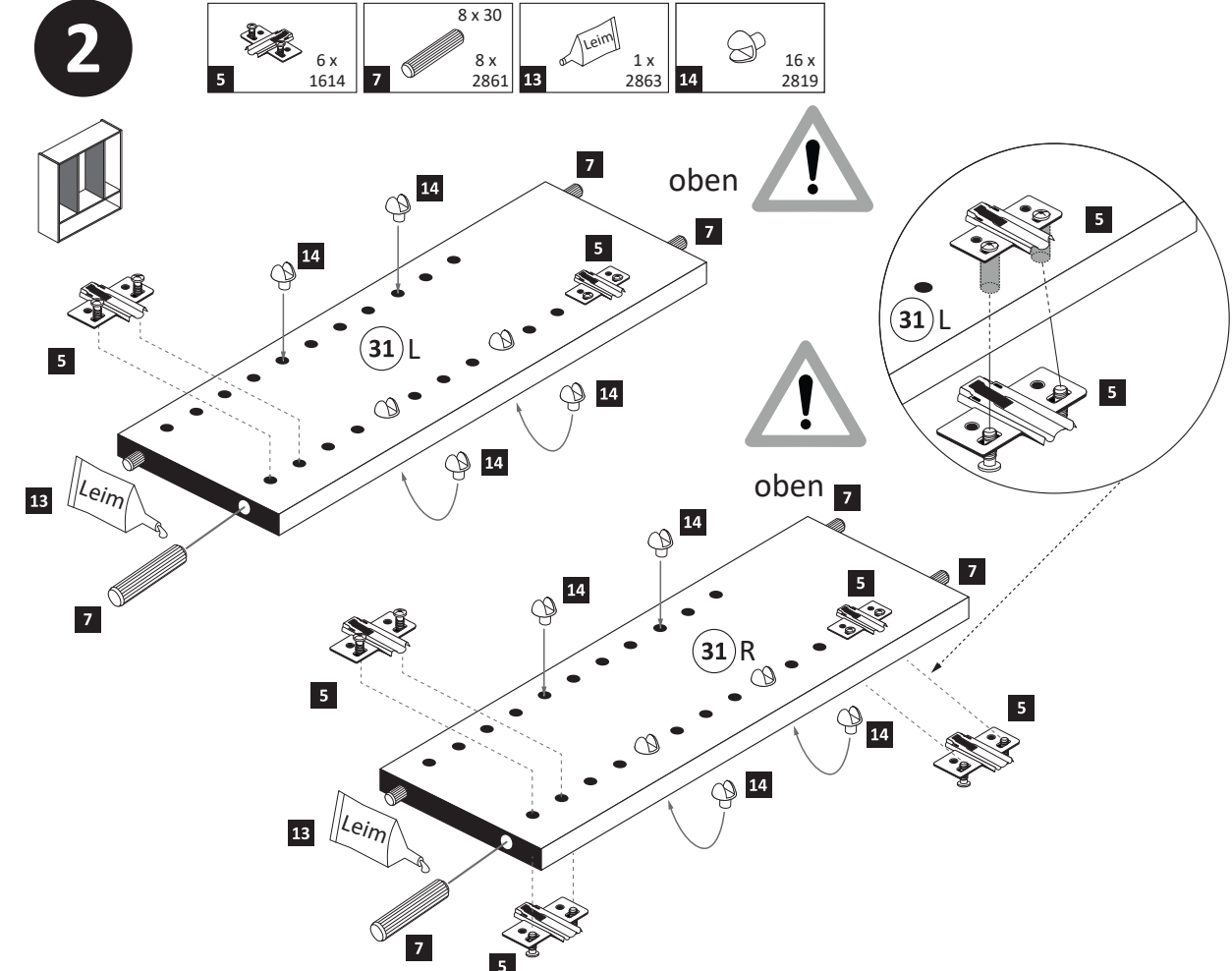
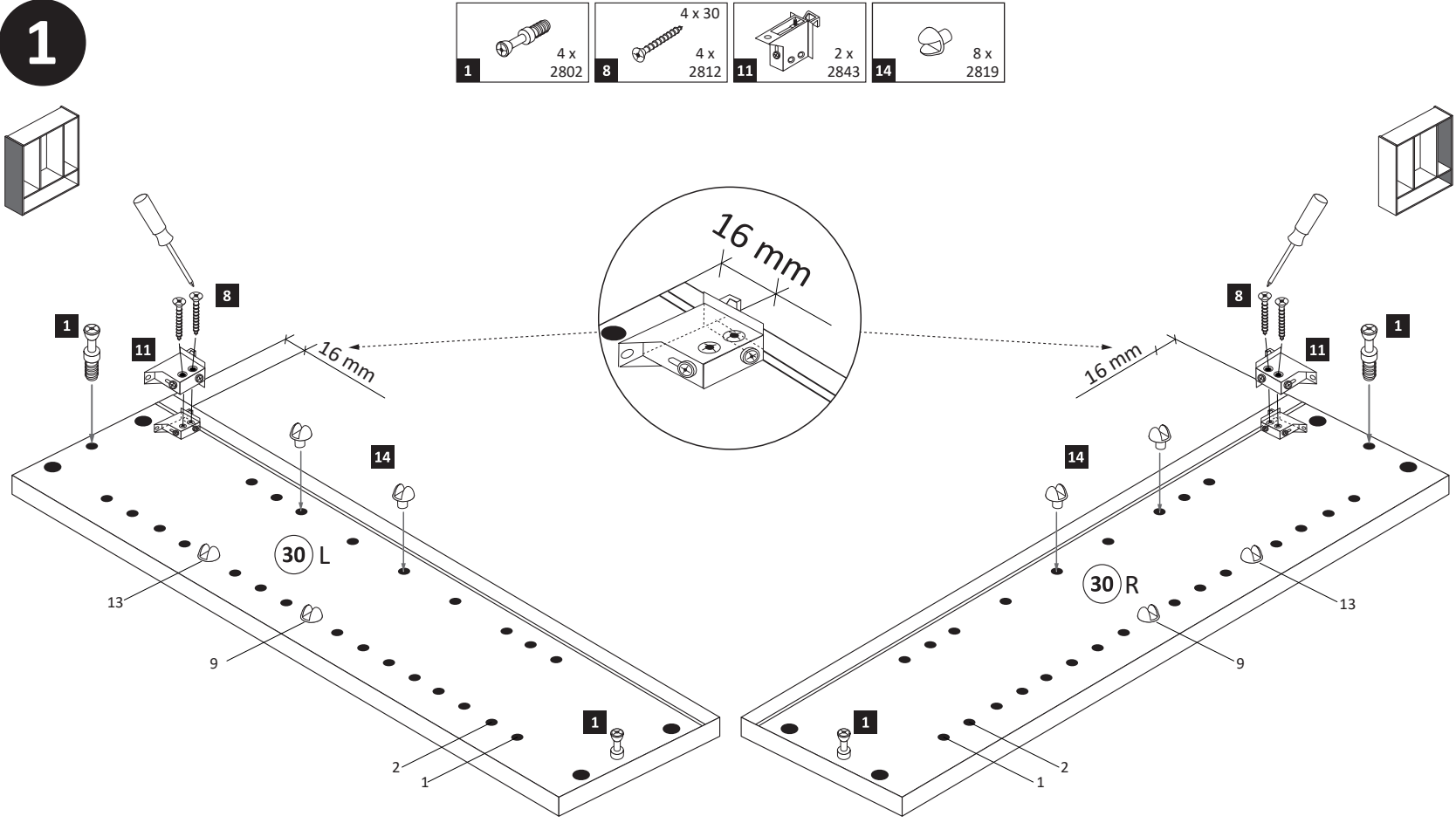
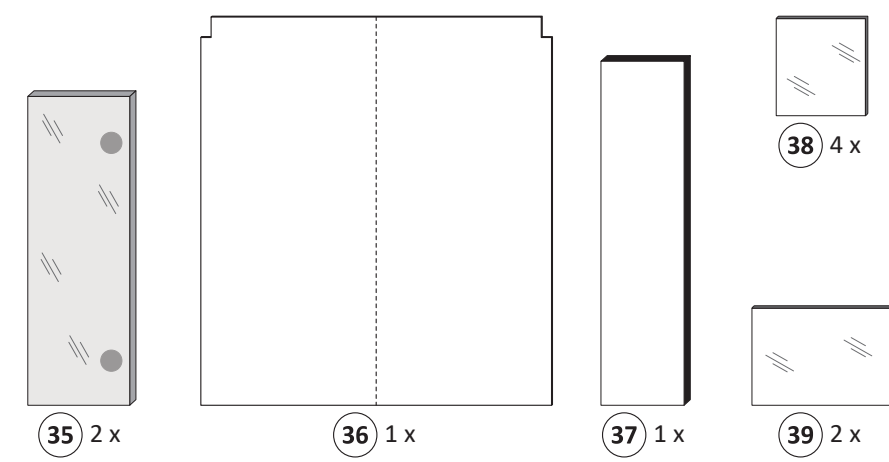
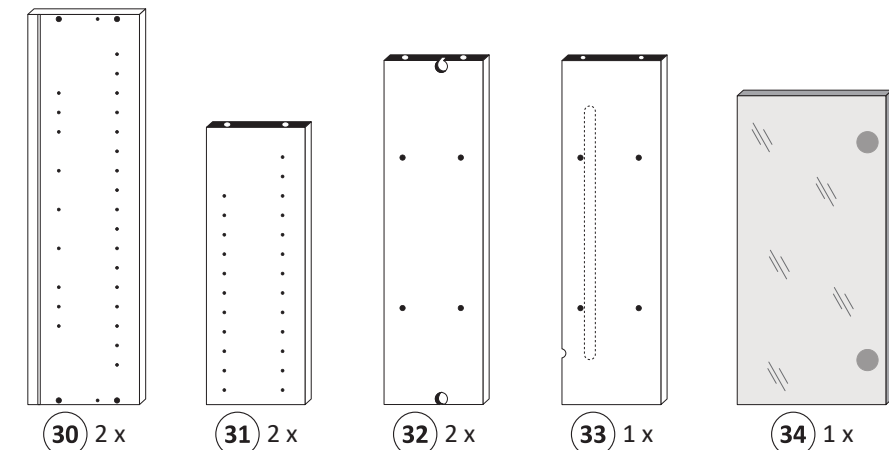

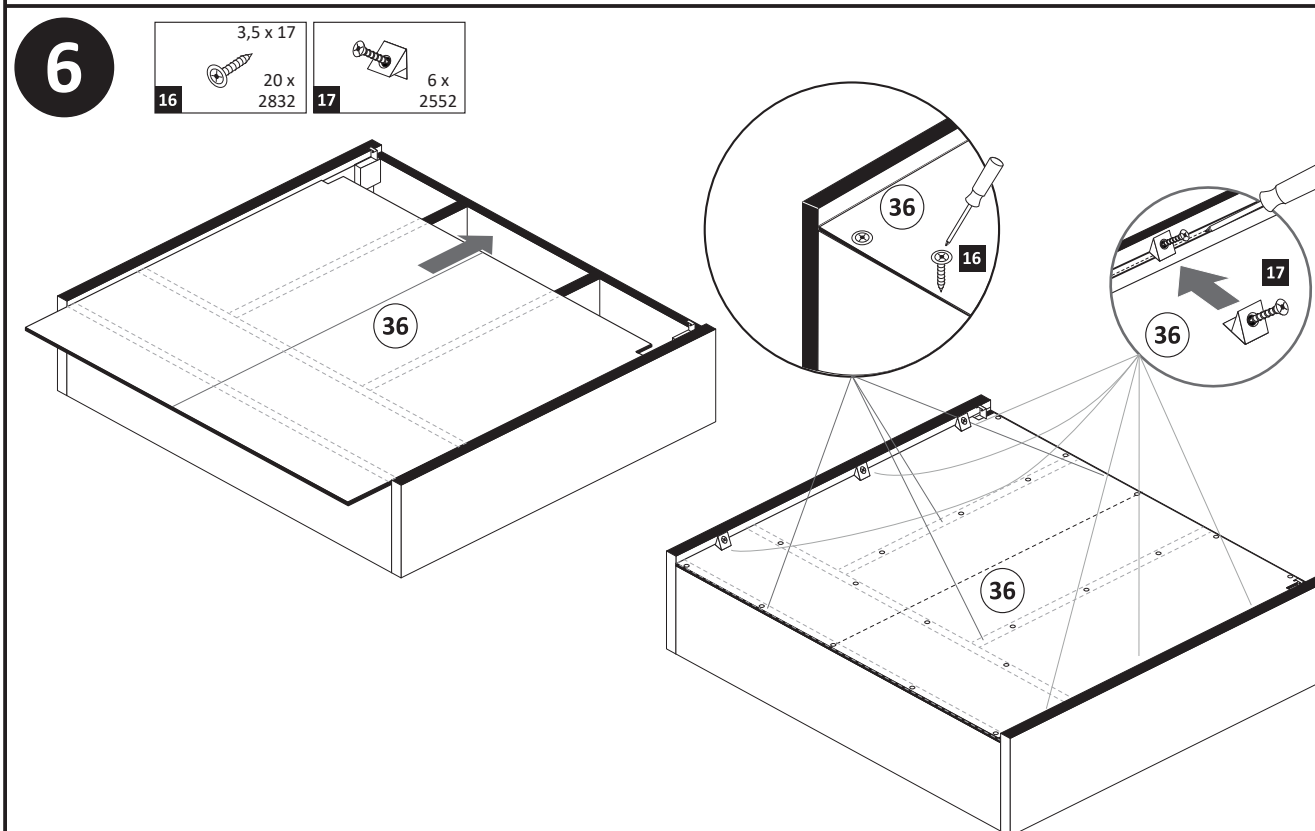
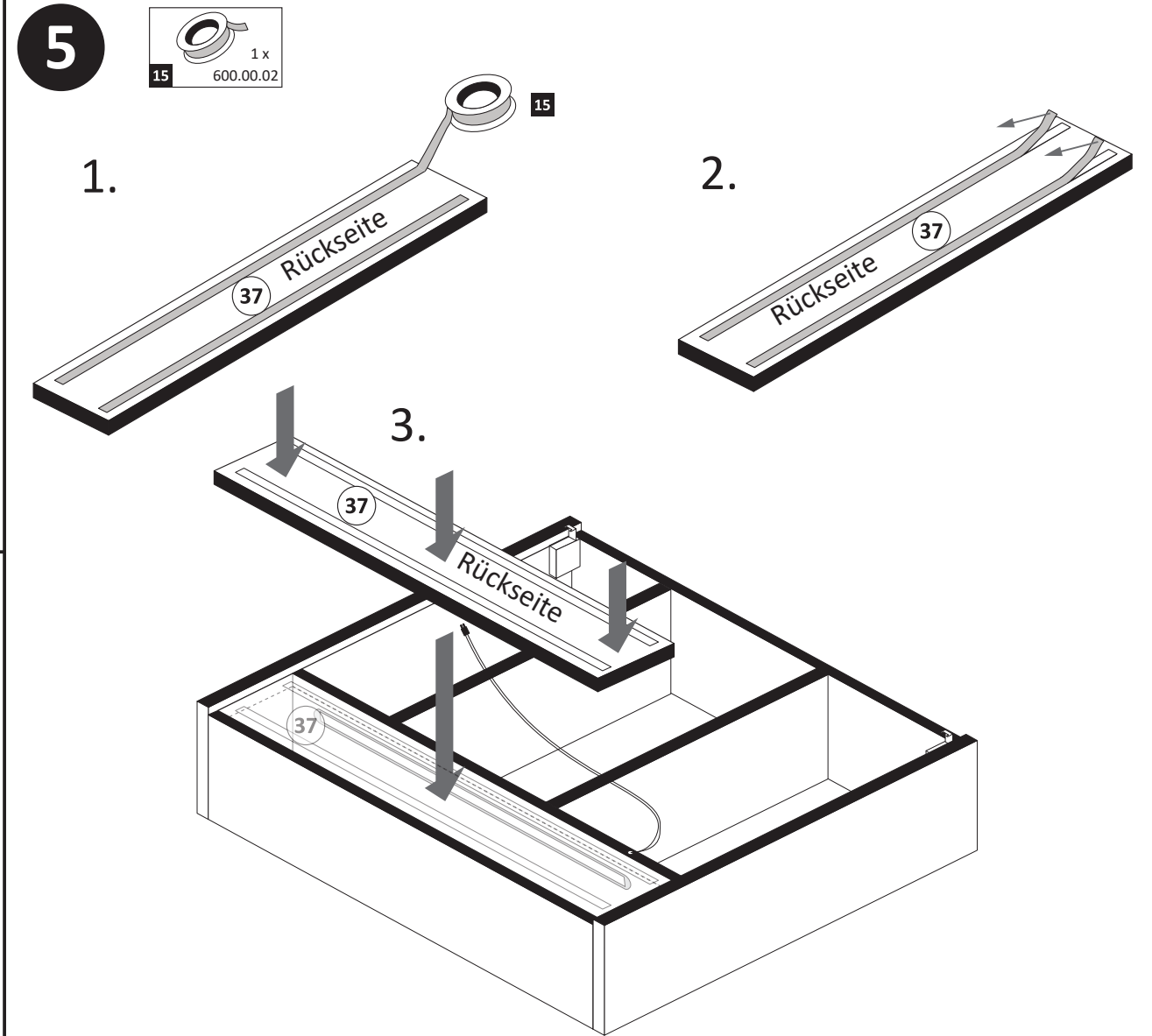
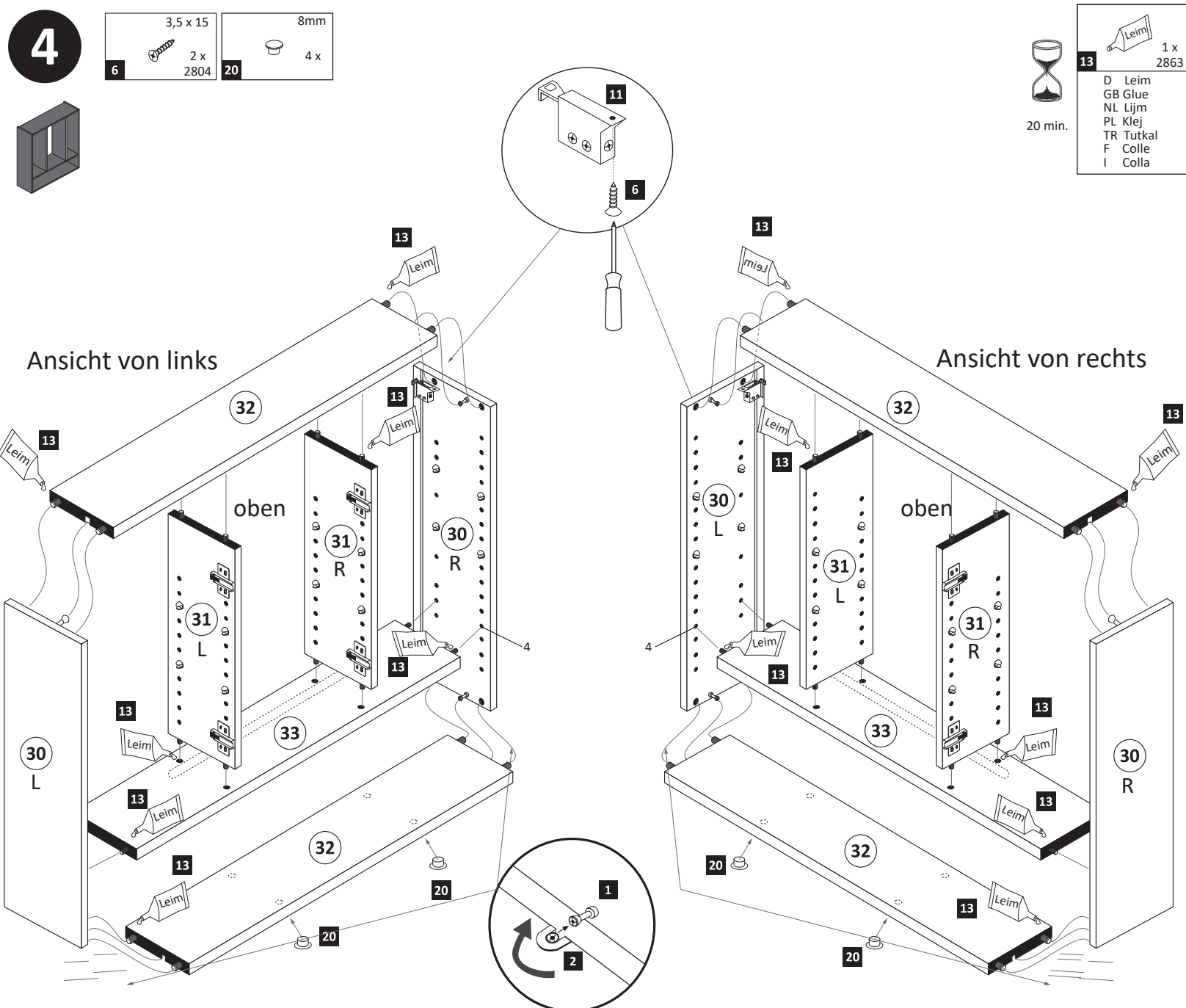
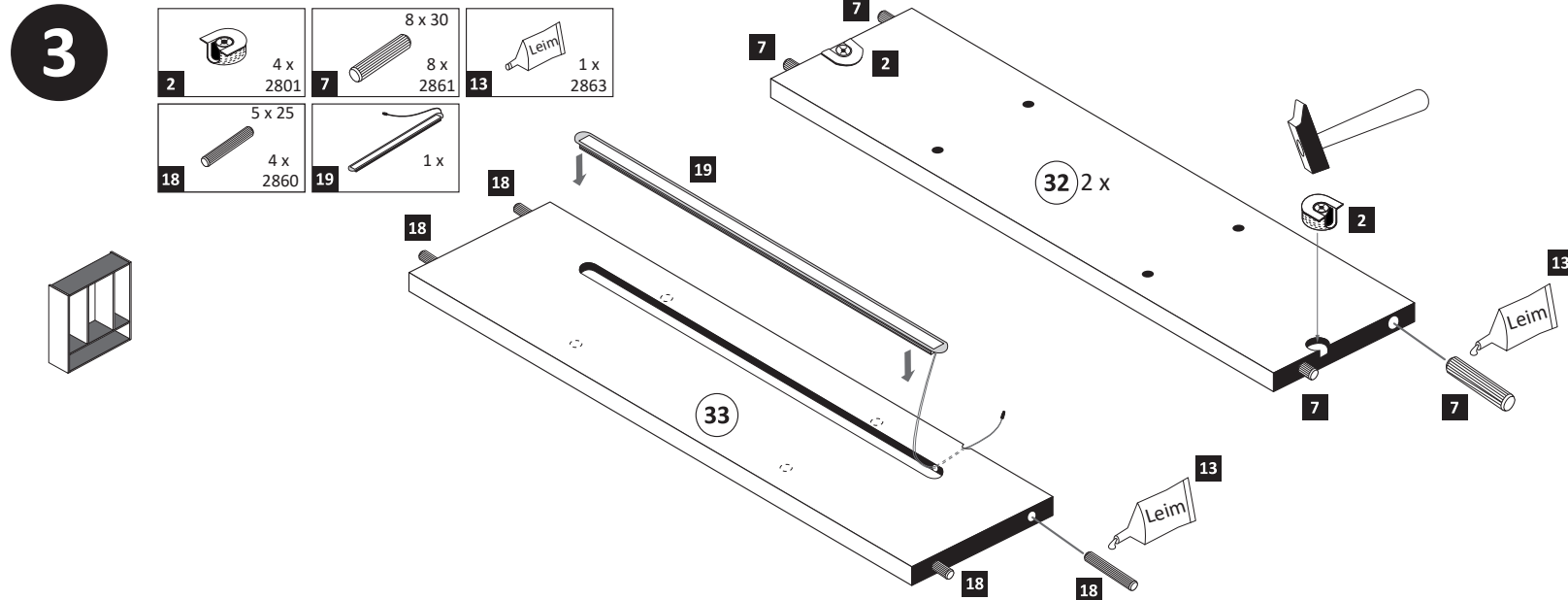

7

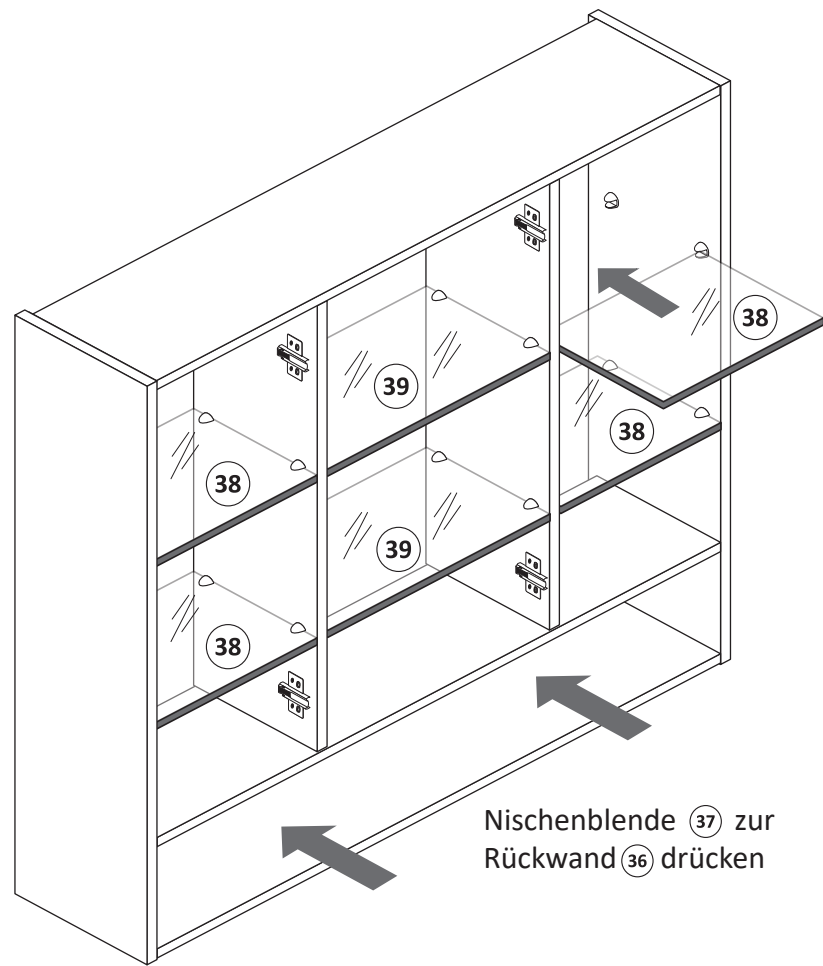

9

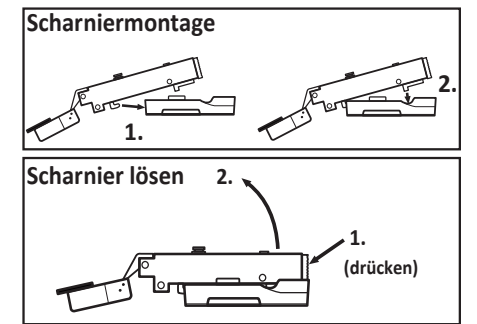
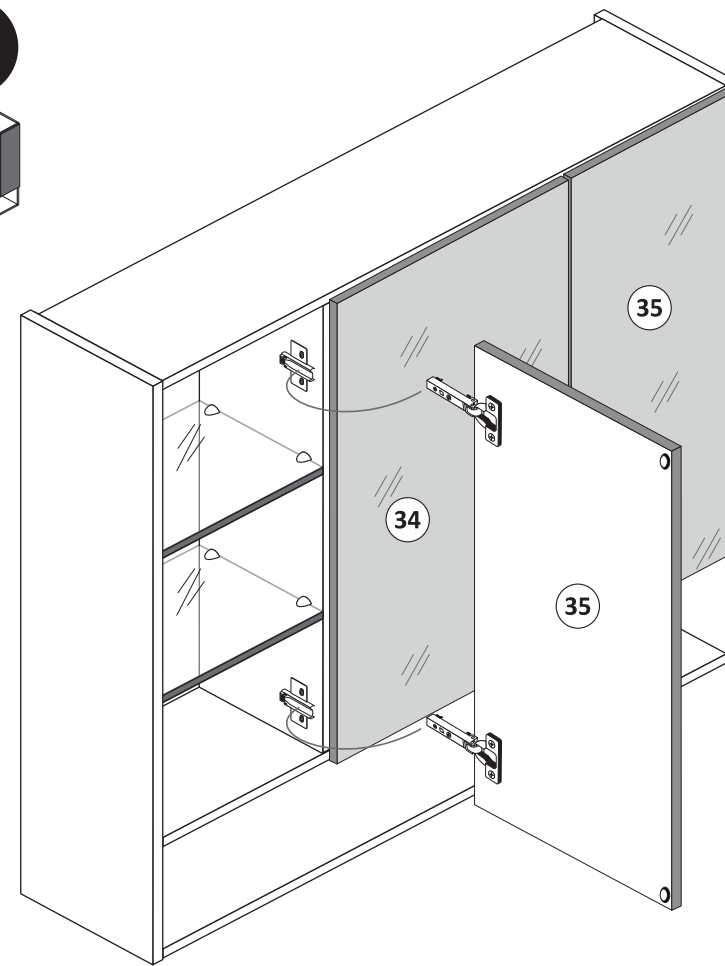
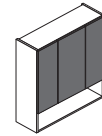

8

gedämpft	ungedämpft	3,5 x 15	
3 x 1506	3 x 1507	12 x 2804	6 x 2865

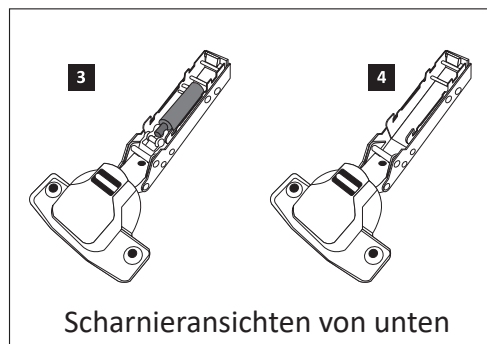

10

5,8 x 55	8 x 30
2 x 2840	2 x 2842

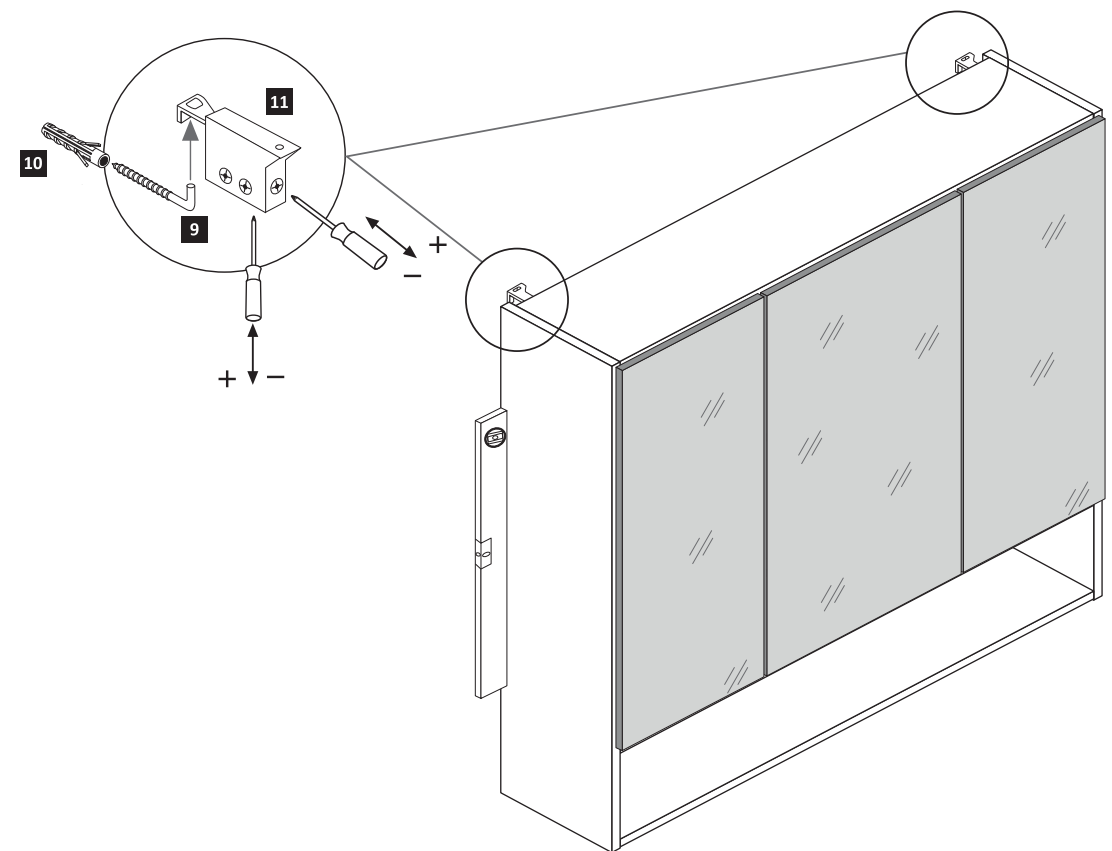

11

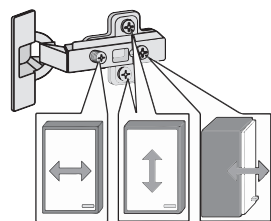
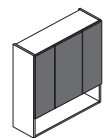
3,5 x 15
12 x
2804
6

1. Türen einstellen.

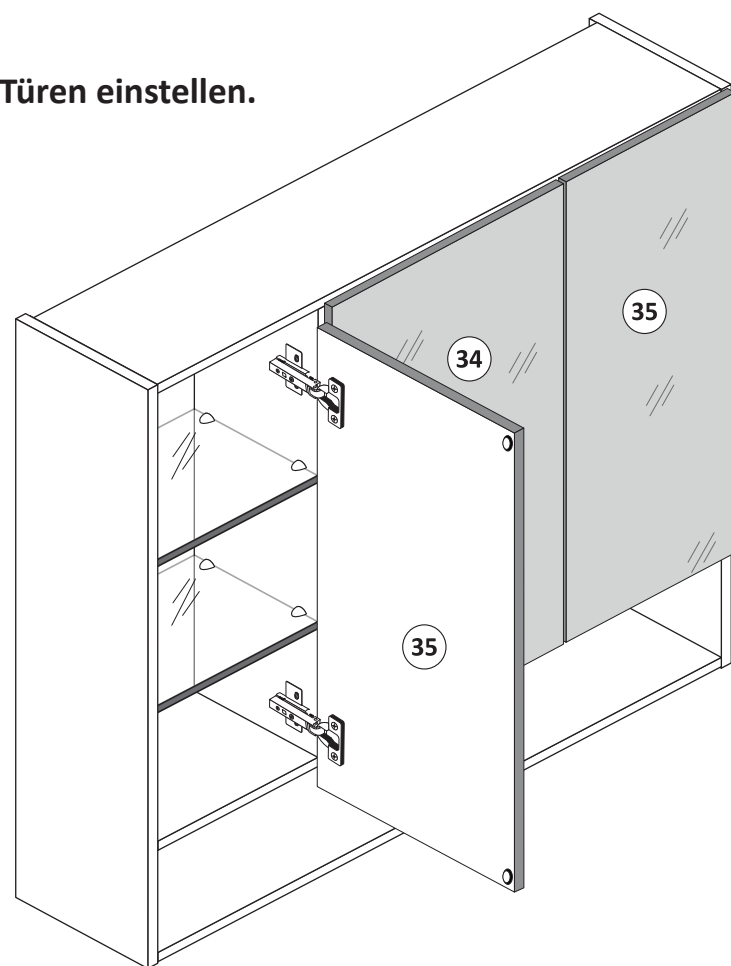

Achtung !!
Aus Sicherheitsgründen ist die Montage der
Sicherungsschrauben zwingend notwendig.
Nachdem montieren der Sicherungsschrauben
ist die Höheneinstellung der Türen nicht mehr
möglich!

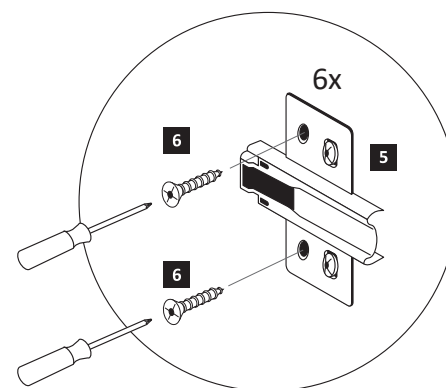

2. Sicherungsschrauben montieren.

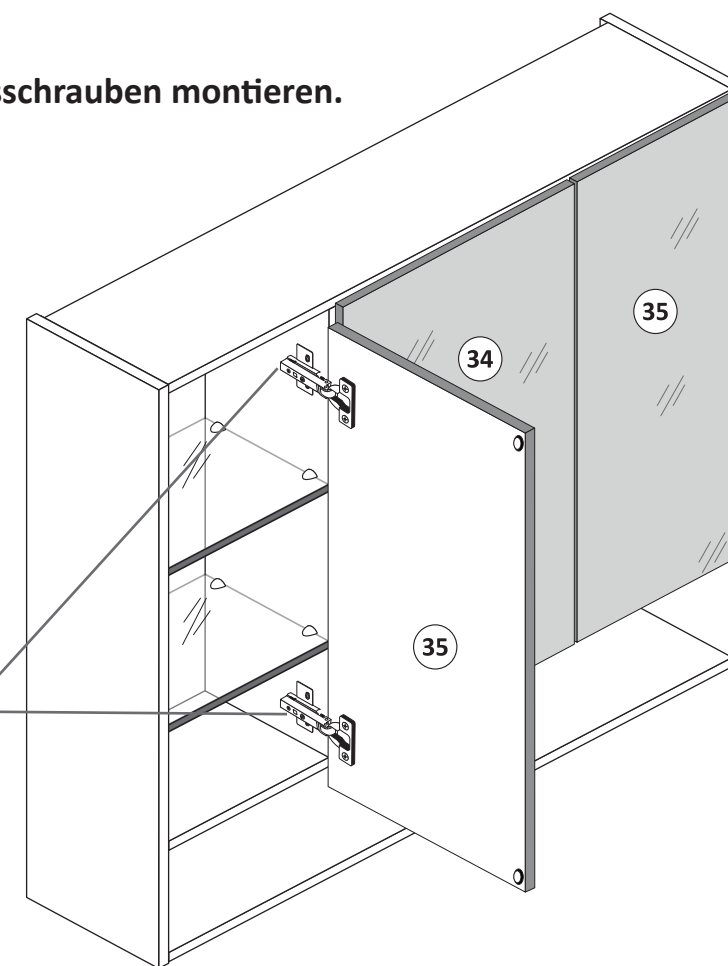



89941.334

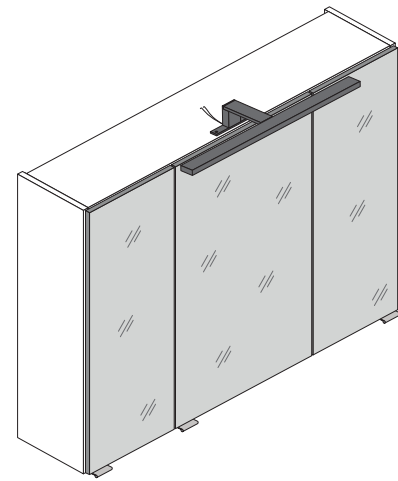
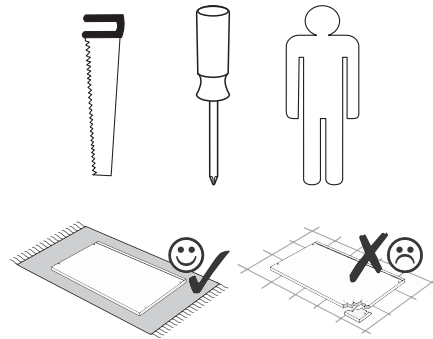
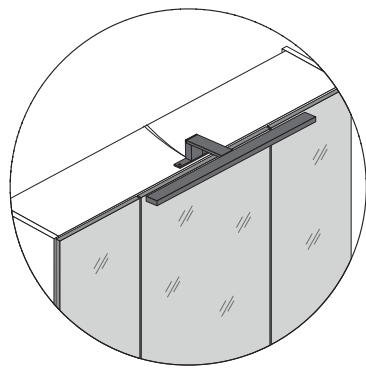

Variante A

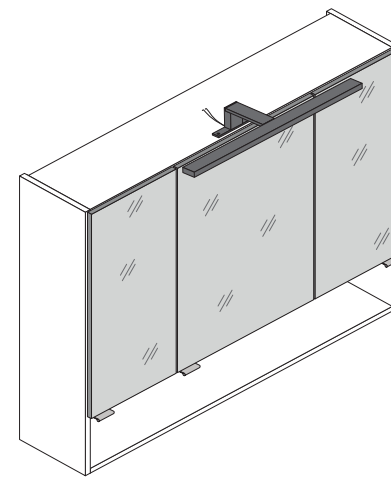

Variante B

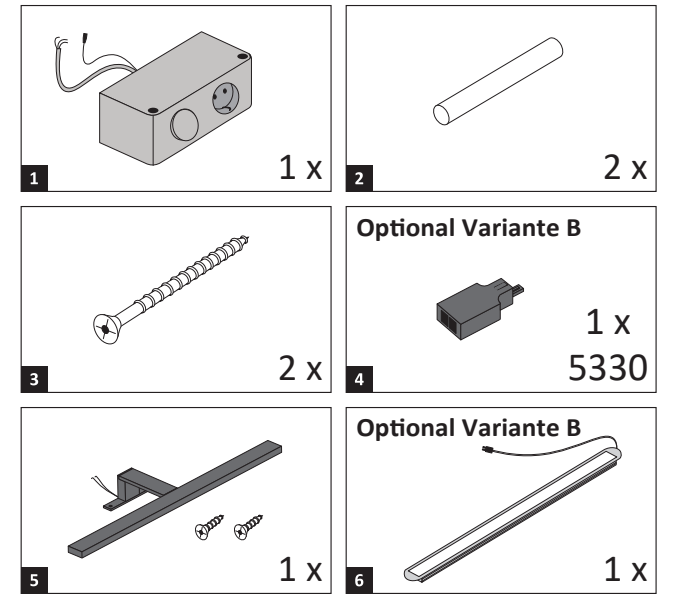

1

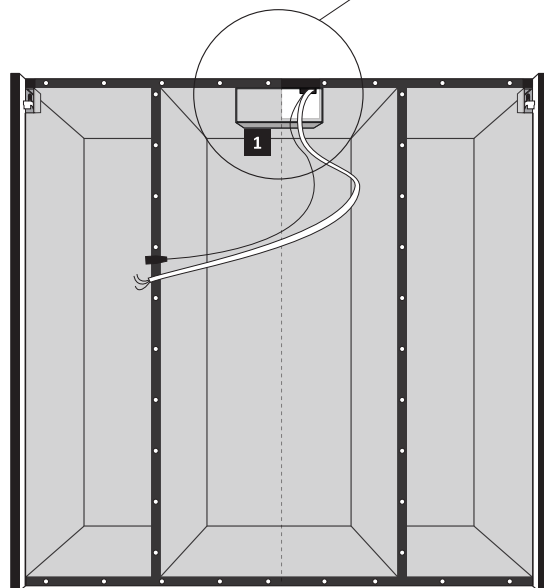
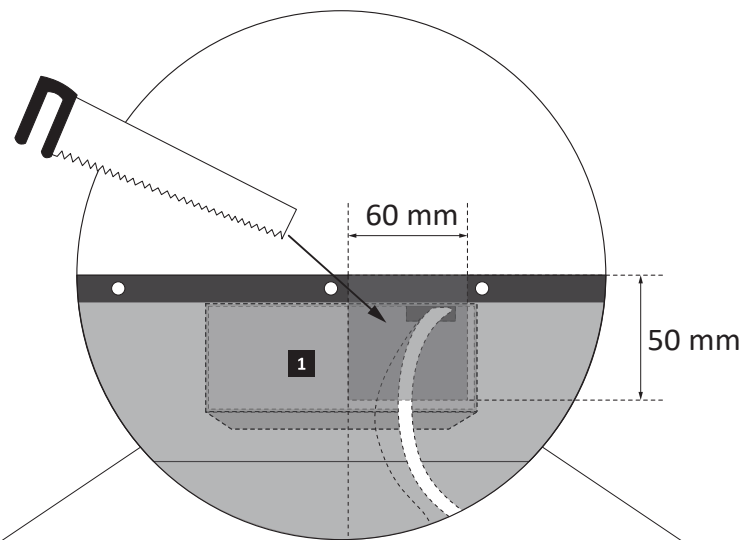

Variante A

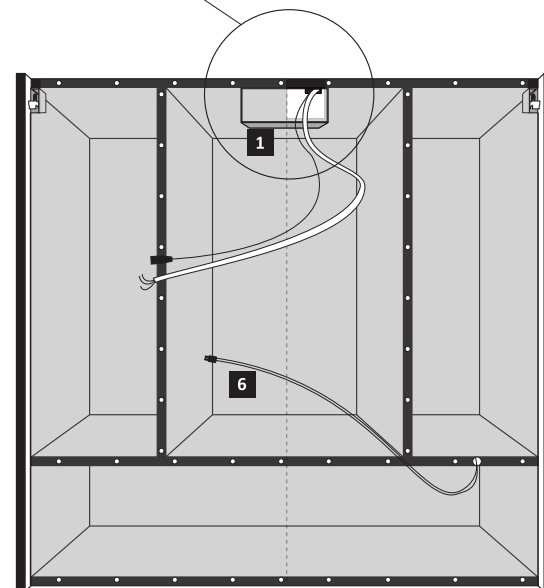

Variante B

2

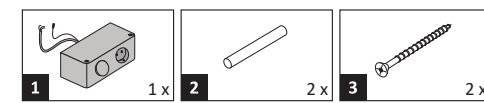

2.

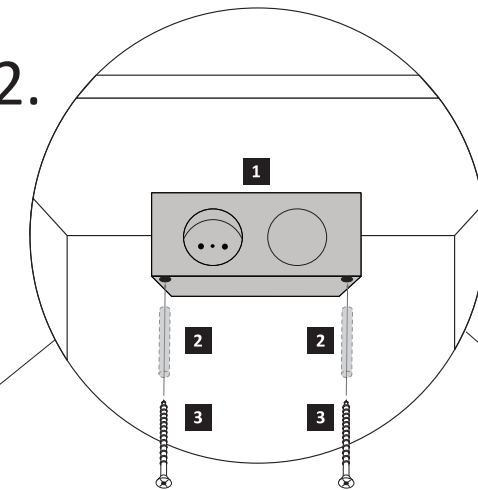

1.

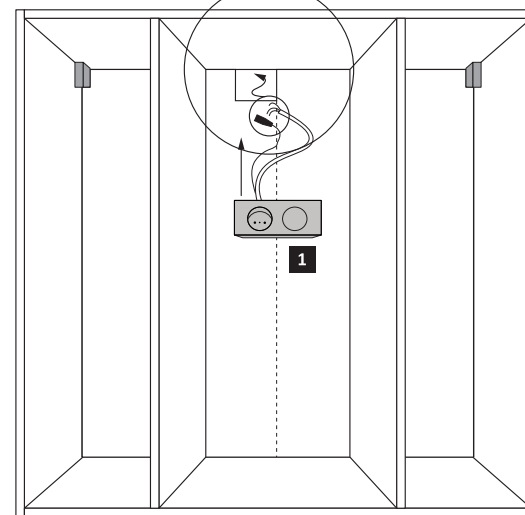

Variante A

1.

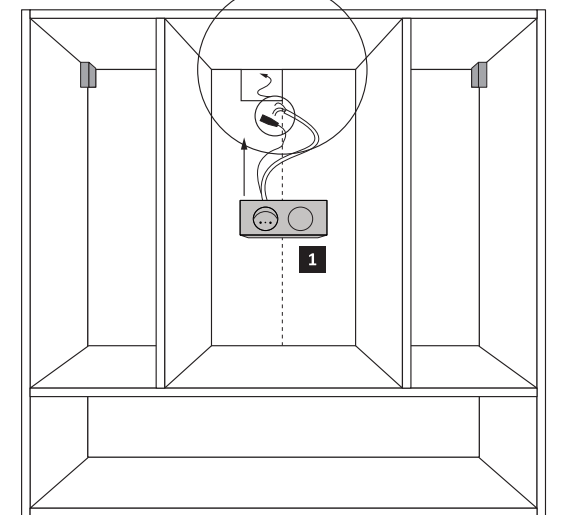

Variante B

3

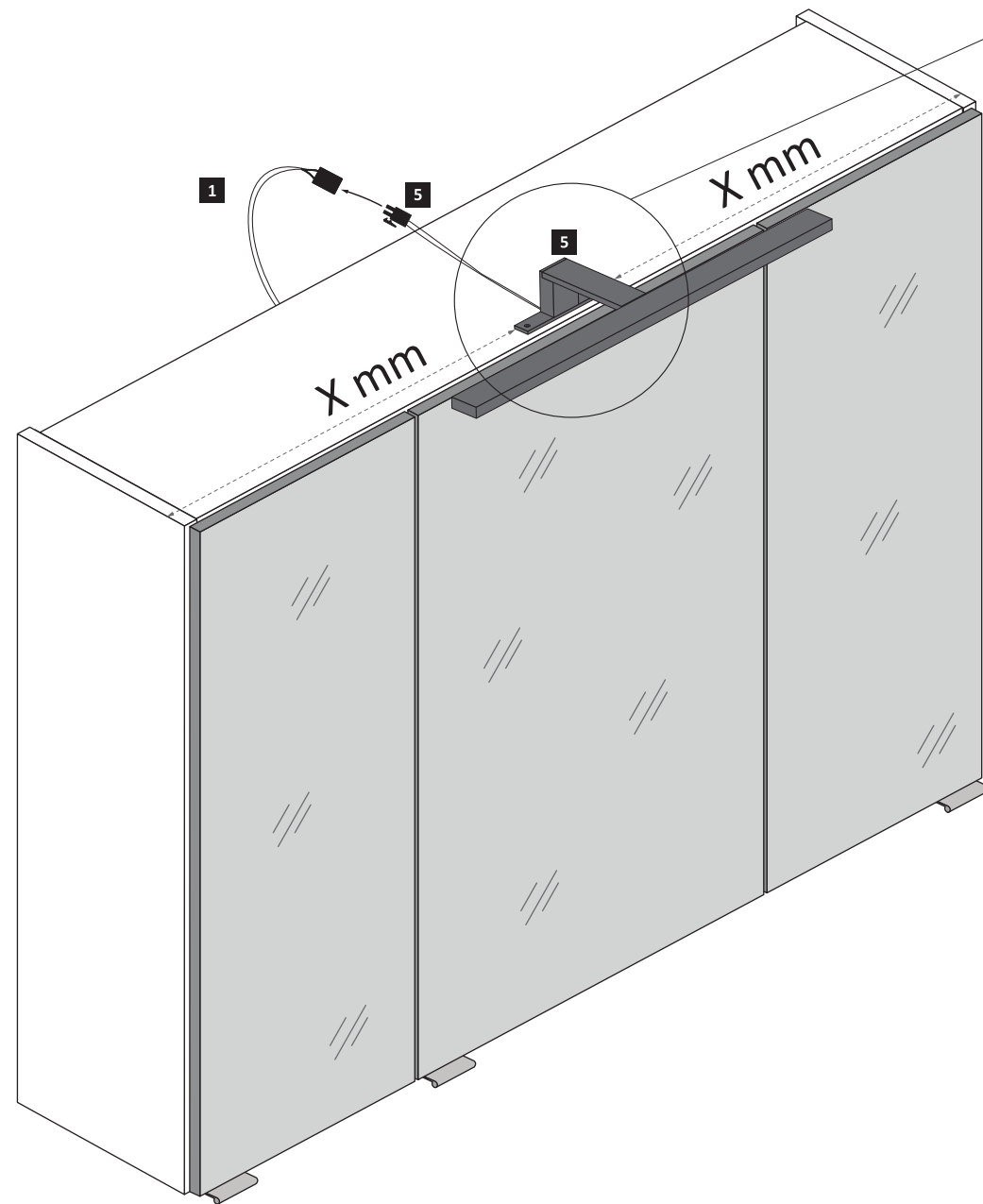
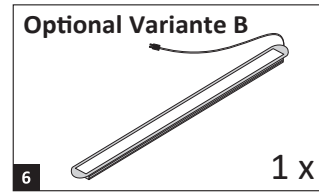
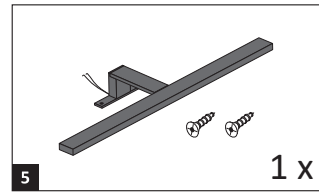
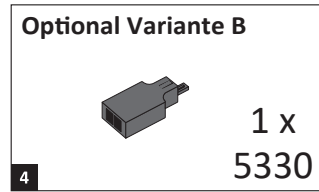
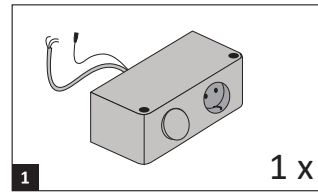

Variante A

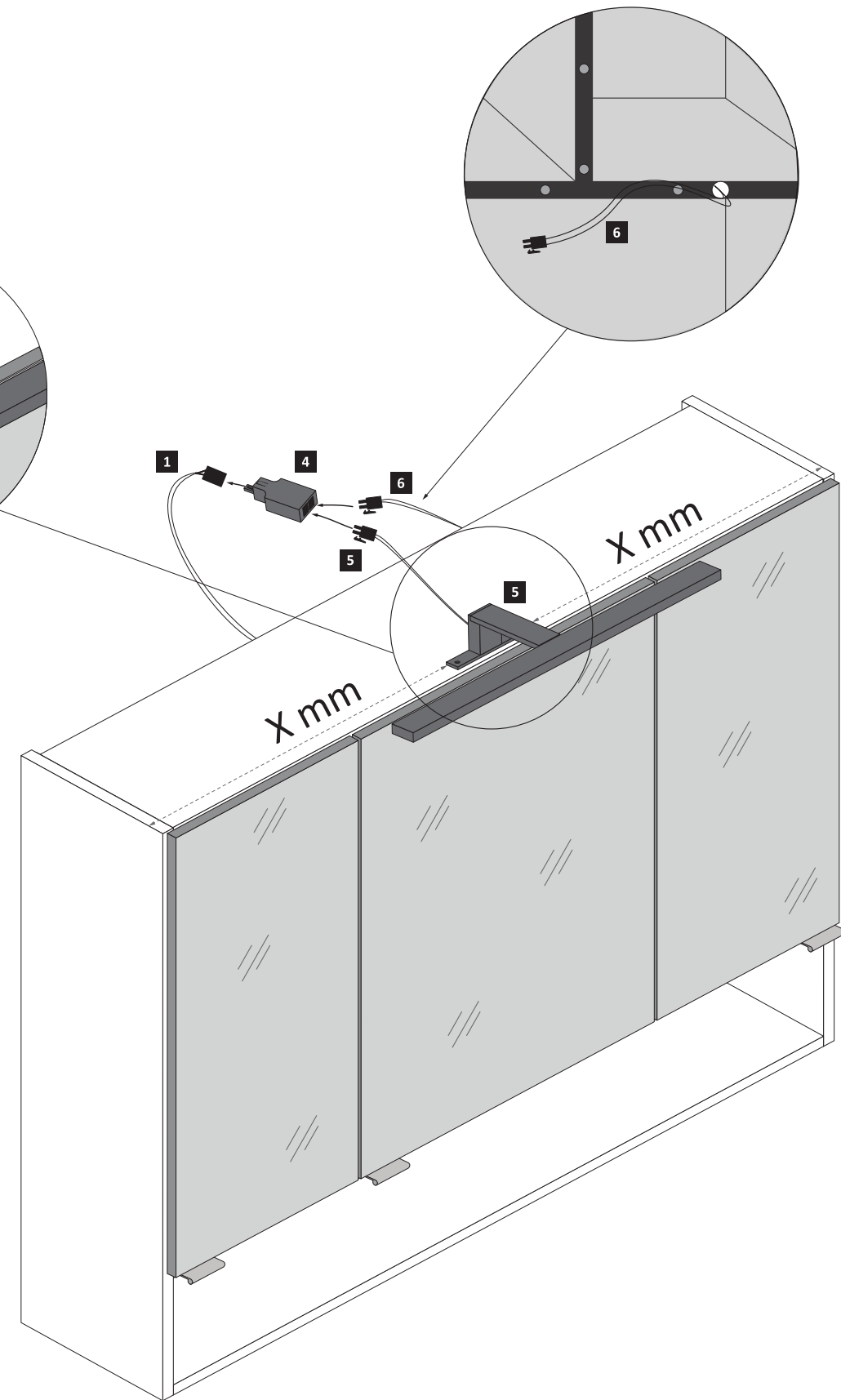
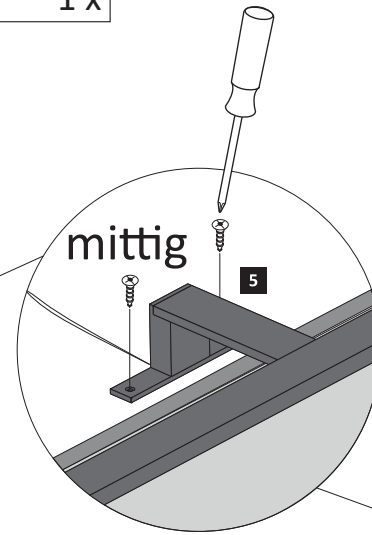

Variante B



89944.330

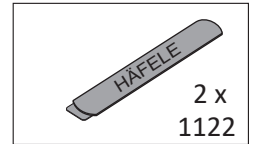
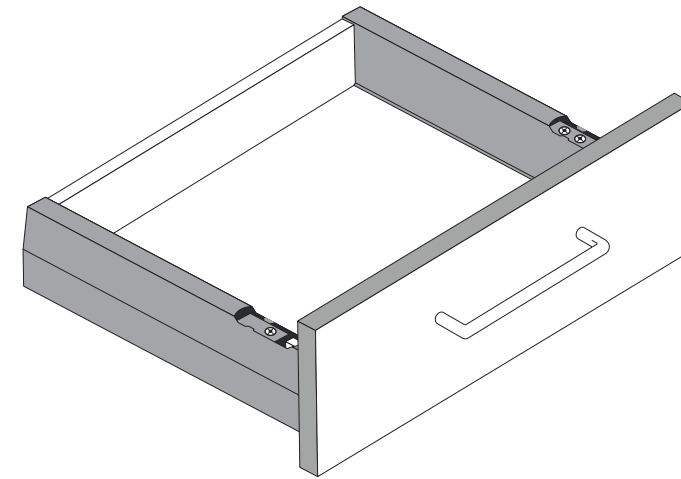
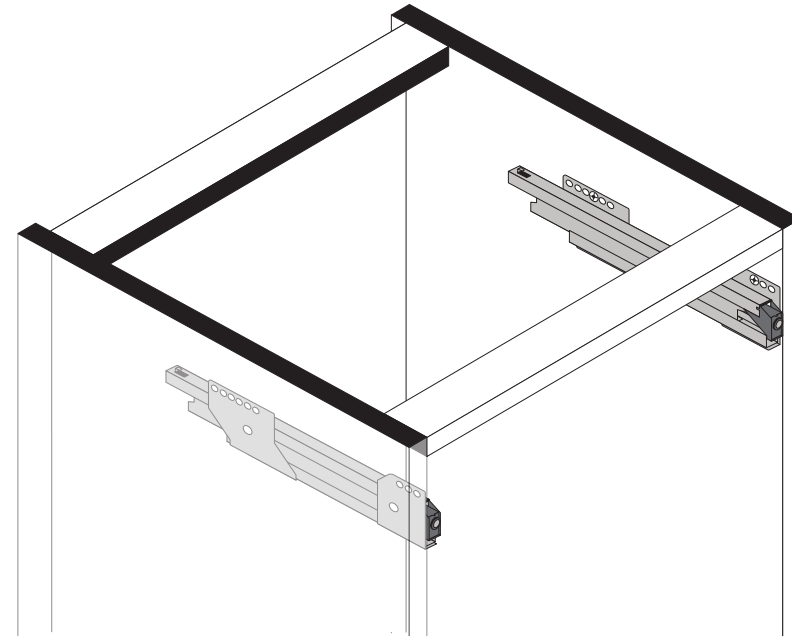
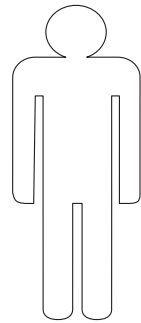

1

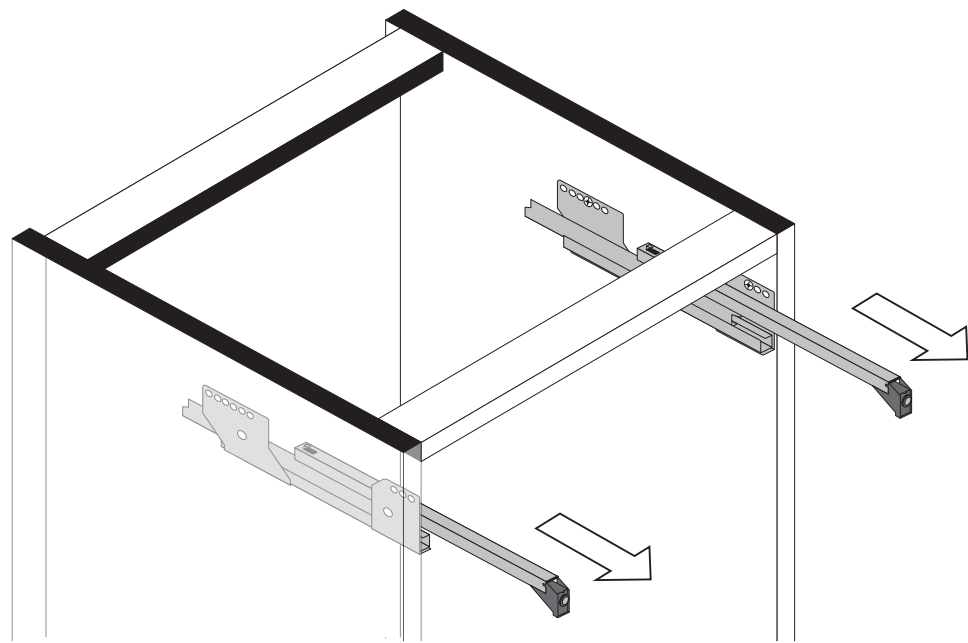

2

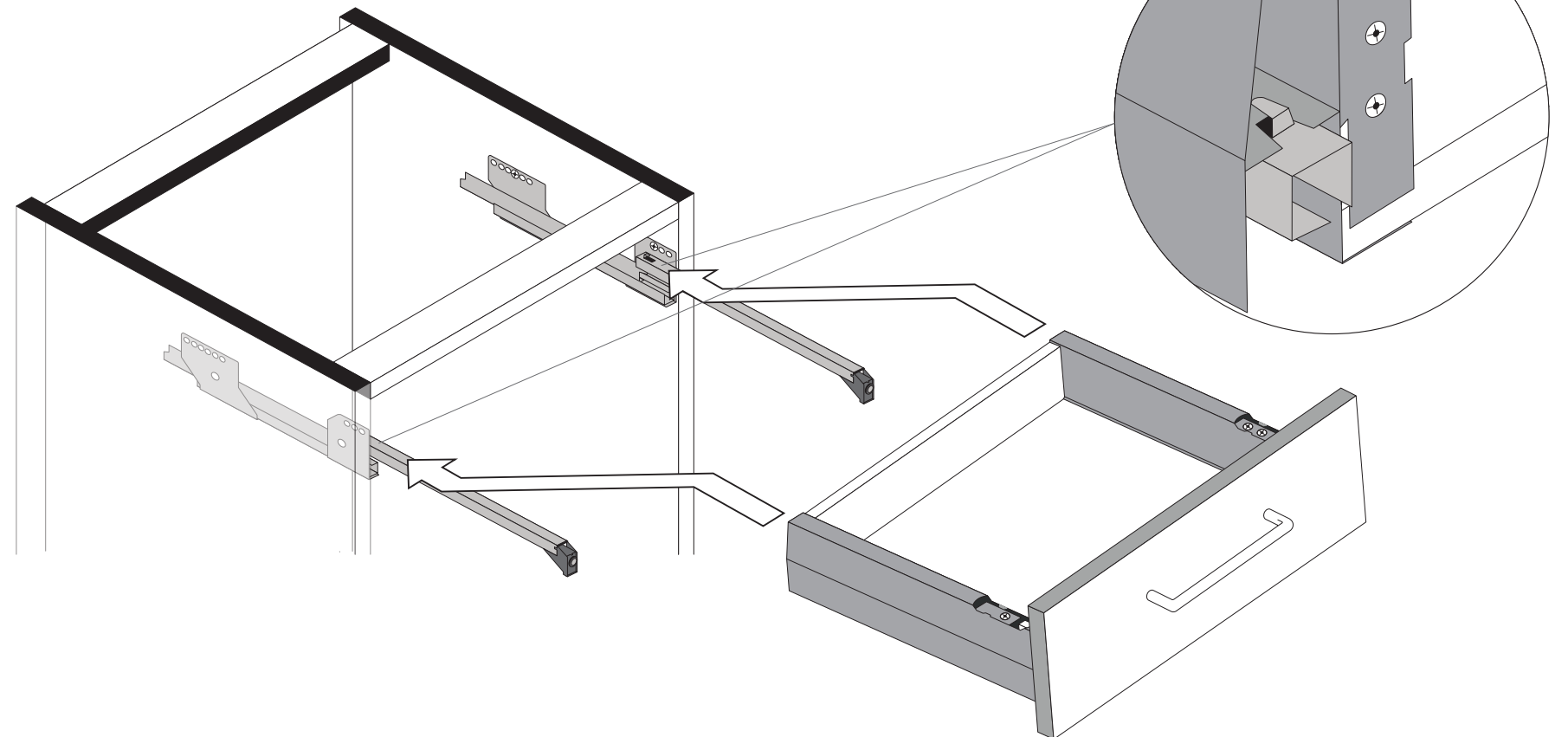

3

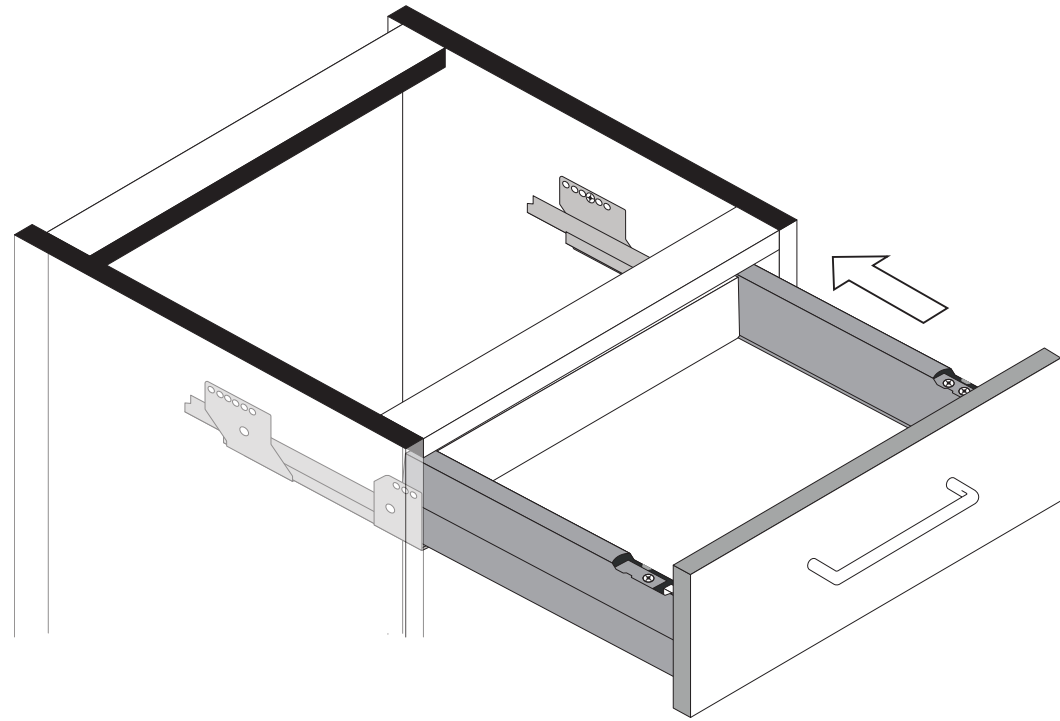

4

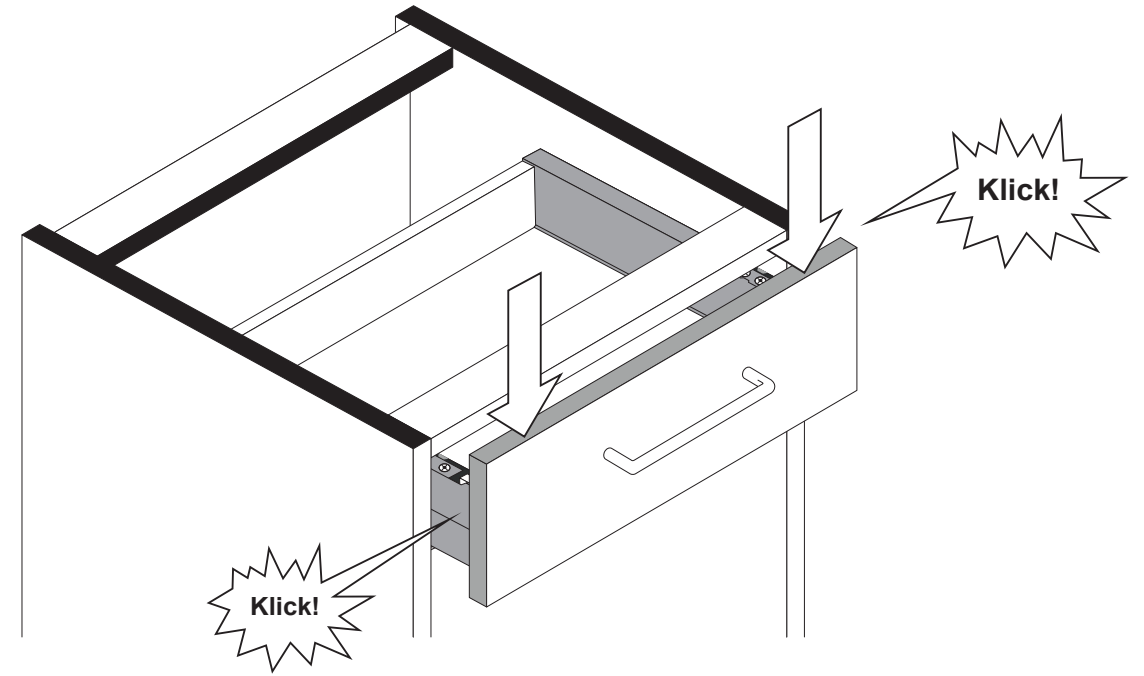

5



6

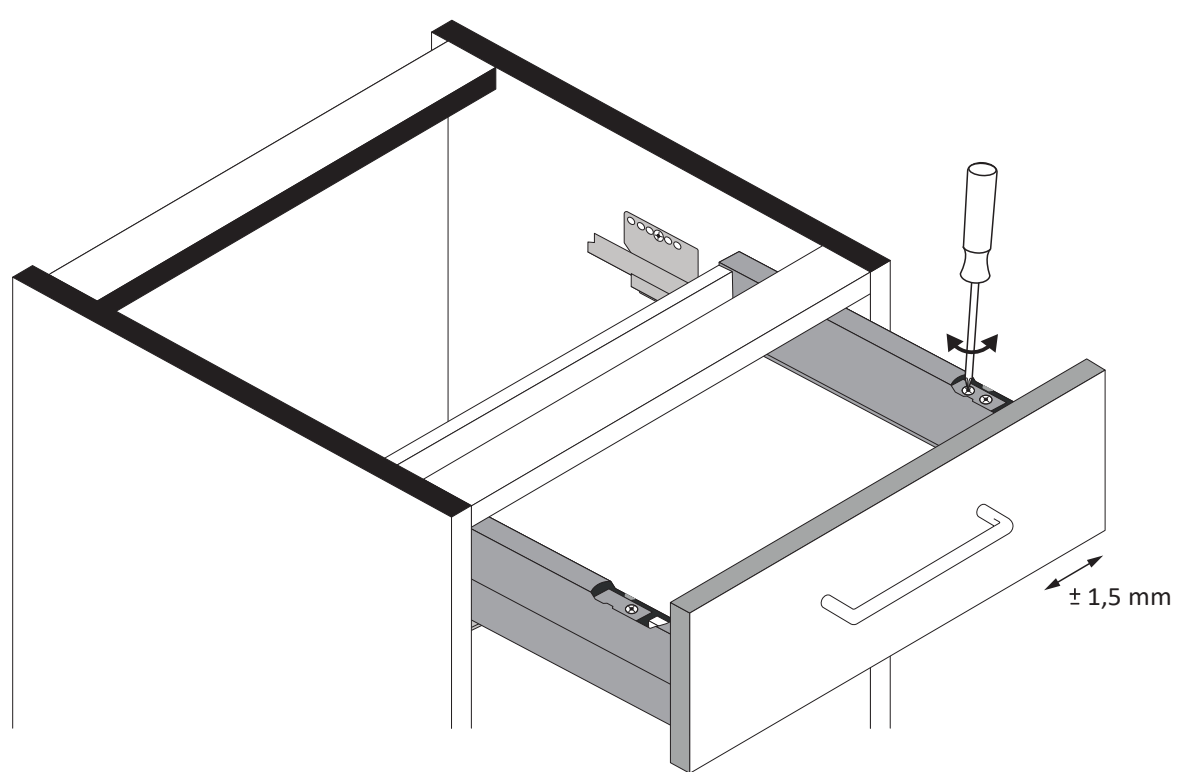

7

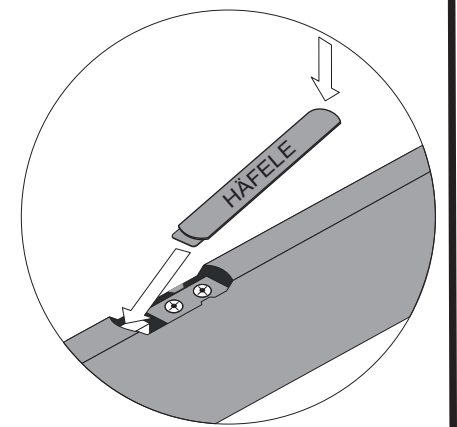



88844.311

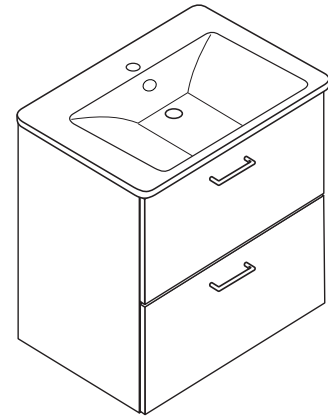
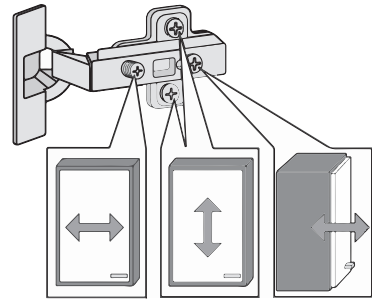
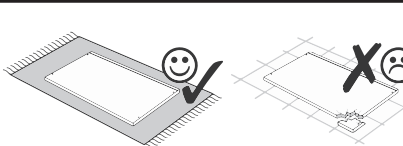
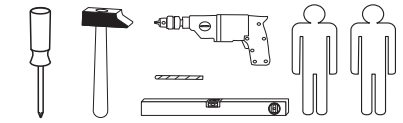

1 4 x 2802	2 4 x 2801	3 6,3 x 11 8 x 2815	4 3,5 x 15 28 x 2804	5 8 x 30 12 x 2861	6 8 x 5 2 x 2855
7 1 x 2863	8 2 x 2865	9 4 x 22/25 4 x 2816	10 4 x 2865	11 4 x 1121	12 6,3 x 16 8 x 2816
13 5,8 x 55 2 x 2840	14 8 x 30 2 x 2842	15 R 1 x 2881	16 L 1 x 2880	17 4 x 30 2 x 2830	18 4 x 1122
19 2 x 5285.400	20 2 x 5284.400	21 Silikon 25ml 1 x 1970			

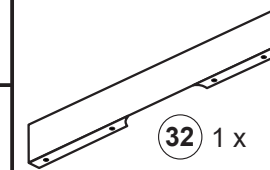
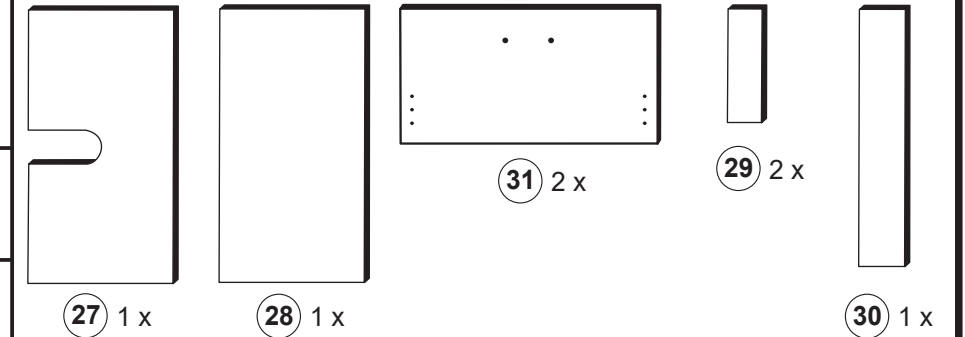
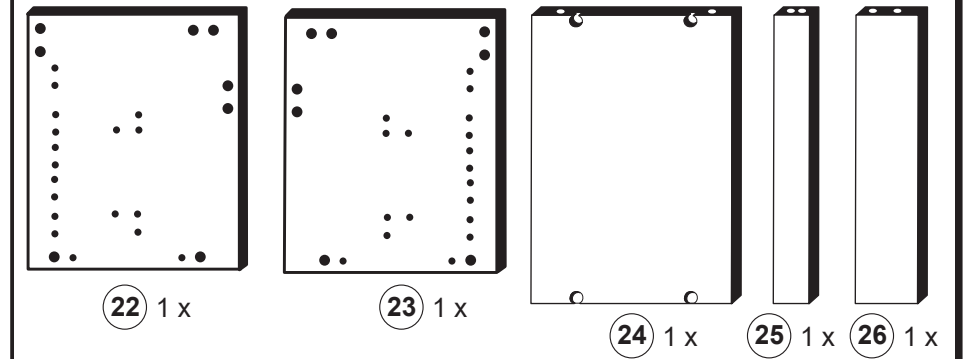
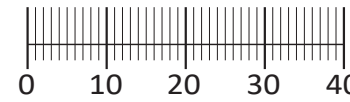

Das beigegefügte Wandbefestigungsmaterial (Dübel und Schrauben) eignet sich nur für festes Mauerwerk (z.B.: Beton- oder Ziegelwände). Für andere Wandaufbauten sind eventuell Spezialdübel und andere Schrauben notwendig. Ziehen Sie gegebenenfalls eine Fachkraft zu Rate.

De begeleidende wandmontage hardware (pluggen en schroeven) is alleen geschikt voor massief metselwerk (bijvoorbeeld beton of bakstenen muren). Voor andere muur structuren zijn eventueel bijzondere ankerbouten en andere noodzakelijke. Draai indien nodig, een deskundige.

Приложенный материал для крепления к стене (дюбели и винты) пригоден только для жестких кладок (например, бетонные или кирпичные стены). Для других настенных конструкций необходимы смотря по обстоятельствам специальные дюбели и другие винты. При необходимости проконсультируйтесь у специалиста.

Le mur d'accompagnement matériel de montage (chevilles et vis) ne convient que pour la maçonnerie solide (par exemple en béton ou des murs de briques). Pour les structures de mur d'autres sont peut-être spéciale boulons d'ancrage et d'autres nécessaires. Serrer le cas échéant, un expert.

Zalączony materiał do mocowania do ściany (kolki rozprężne i wkręty) nadaje się tylko do ścian murowanych (np. z betonu lub cegieł). Do ścian wykonanych w innych technologiach konieczne być mogą specjalne kolki rozprężne i inne wkręty. W razie potrzeby skorzystaj z fachowej pomocy

Il muro di accompagnamento hardware di montaggio (tasselli e viti) è adatto solo per muratura piena (ad esempio calcestruzzo o muratura). Per le altre strutture murarie sono forse speciali bulloni di ancoraggio e necessari di altri. Serrare se necessario, un esperto.

The accompanying wall mounting hardware (anchors and screws) is suitable only for solid masonry (eg concrete or brick walls). For other wall structures are possibly special anchor bolts and other necessary. Tighten if necessary, an expert.

Ekteki duvara sabit montaj malzemeleri (dübel ve vidalar), sadece sağlam duvarlar için (örnek: beton veya tuğla) elverişlidir. Başka duvarlar için özel dübeller ve farklı vidalar gerekebilir. Gerekliğinde bir uzmana danışınız.

1

1 4 x 2802	3 6,3 x 11 8 x 2815	19 2 x 5285.400
15 R 1 x 2881	16 L 1 x 2880	

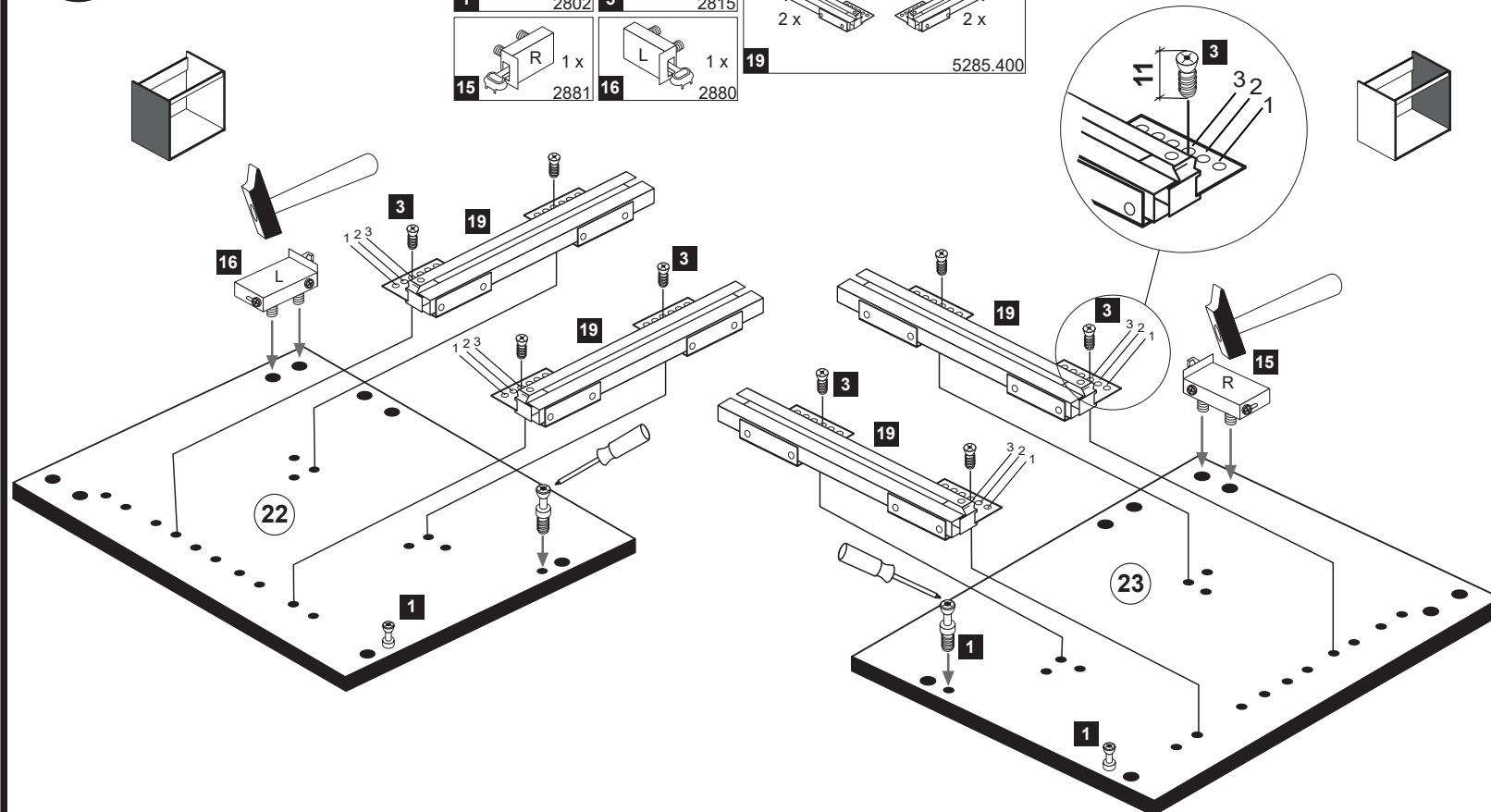

2

2 4 x 2801	5 8 x 30 12 x 2861	7 1 x 2863
-------------------------	------------------------------------	-------------------------

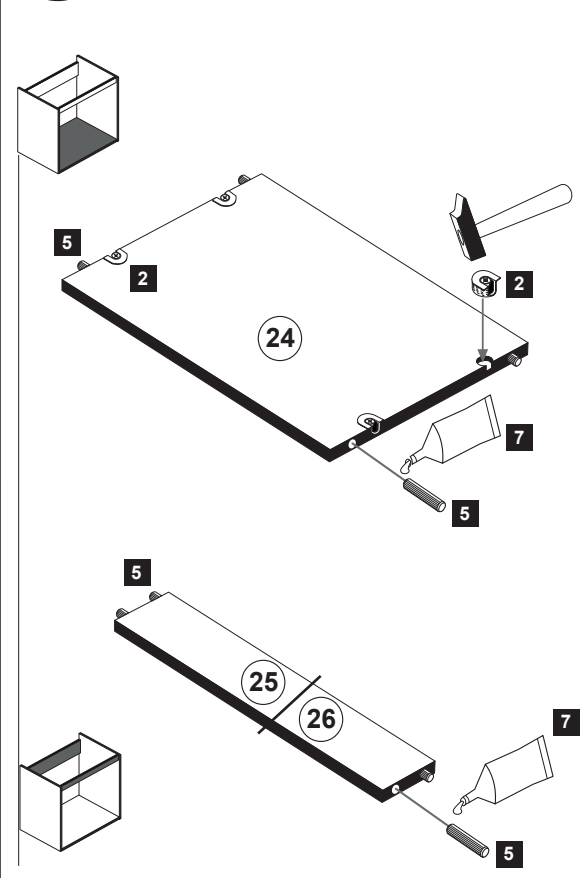

3

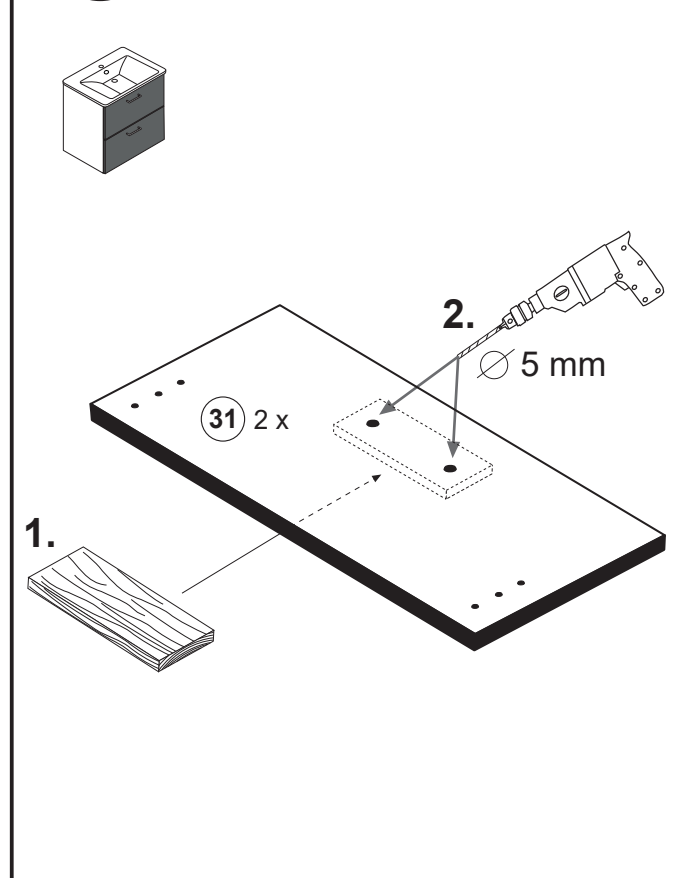

4

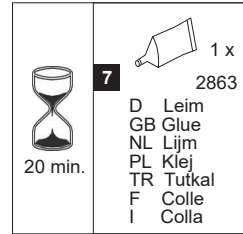
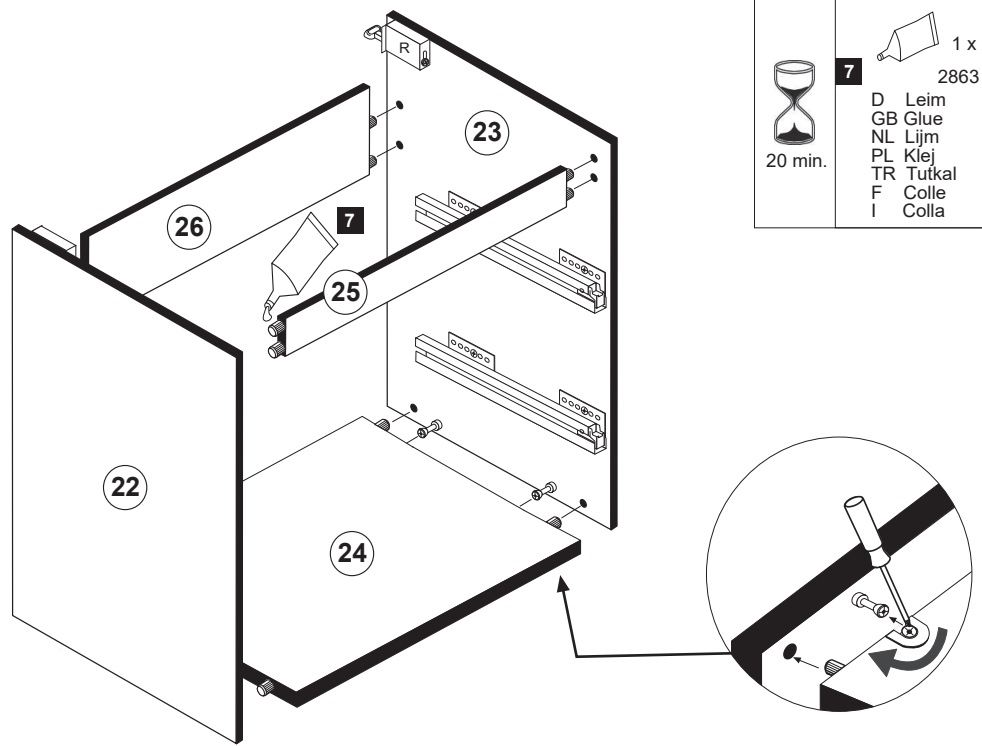

6

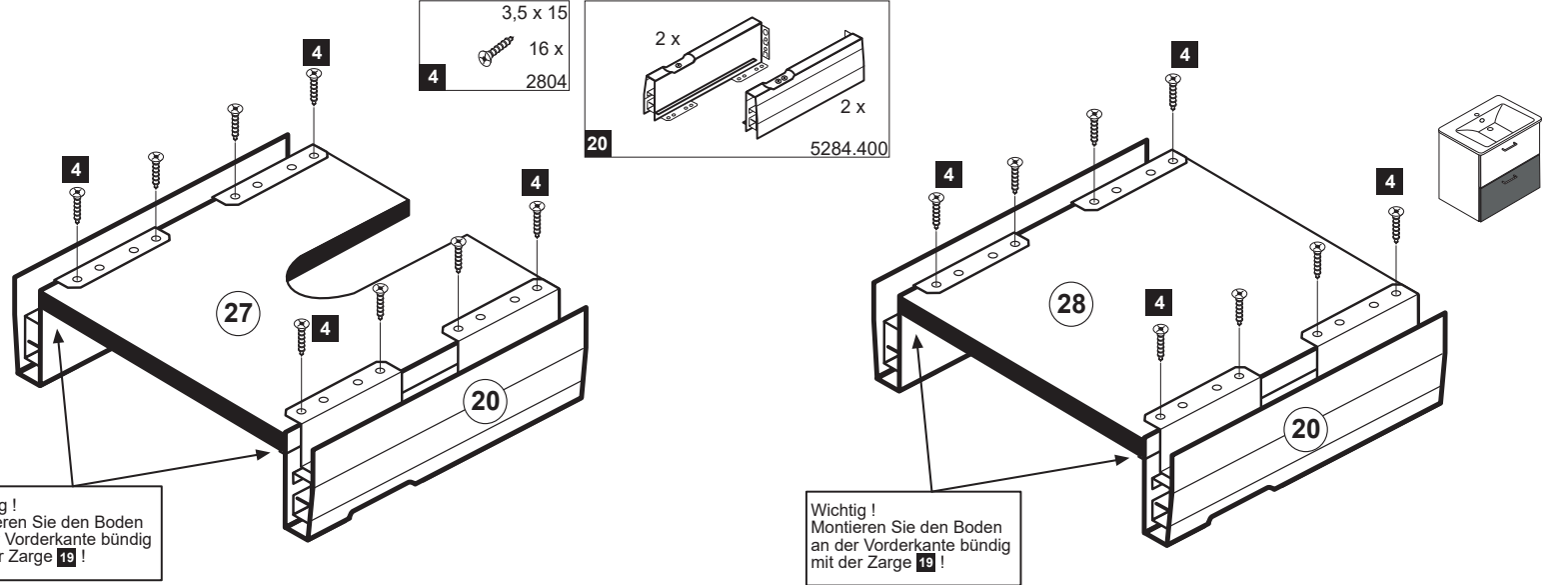

Wichtig!
Montieren Sie den Boden
an der Vorderkante bündig
mit der Zarge 19!

Wichtig!
Montieren Sie den Boden
an der Vorderkante bündig
mit der Zarge 19!

7

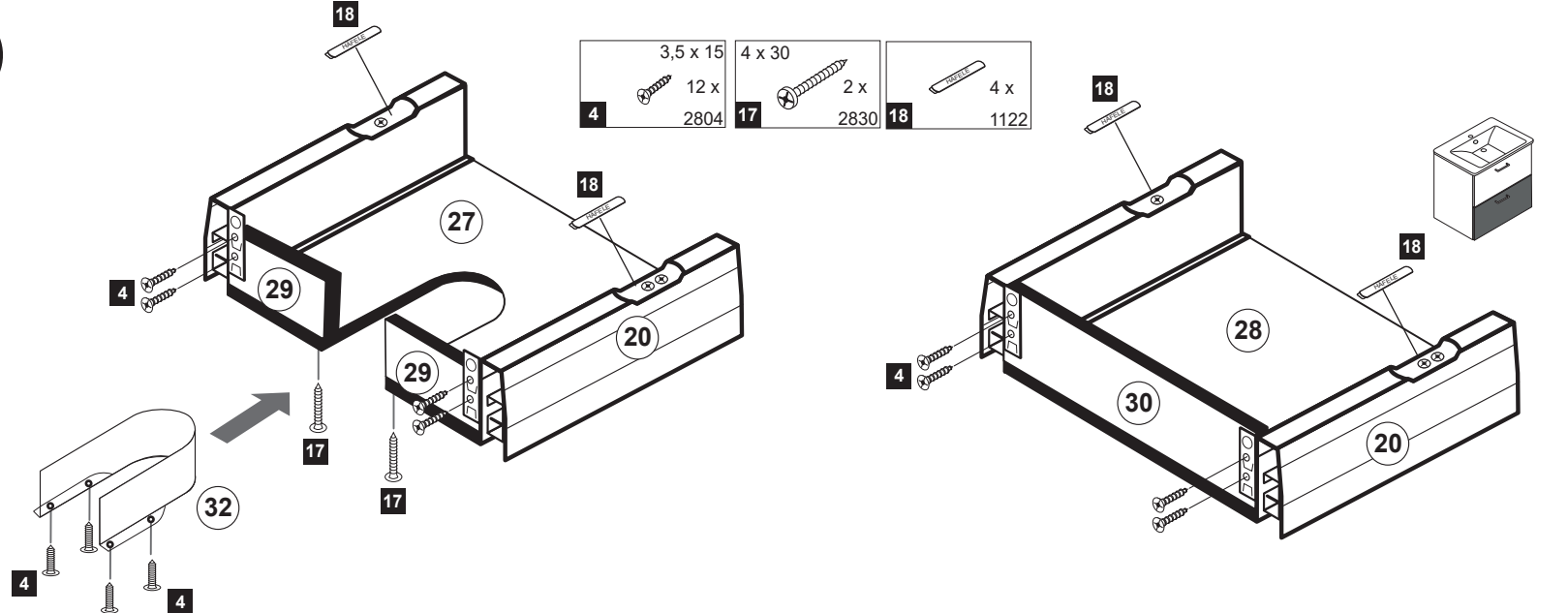
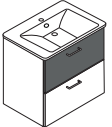

8

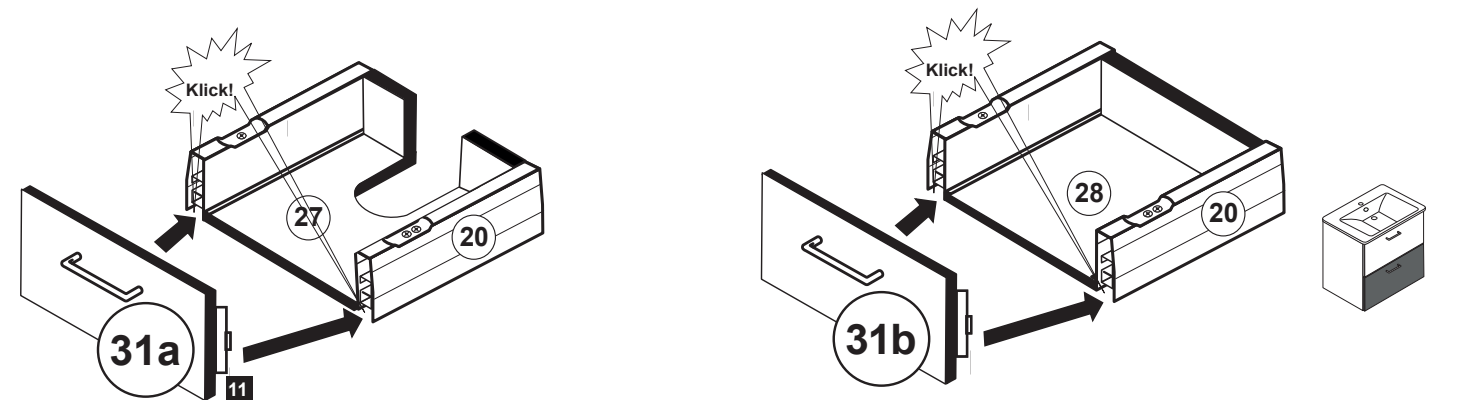
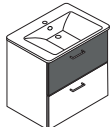
**Hinweis !**

Wie Sie den Schubkasten einhängen müssen entnehmen Sie bitte dem beigefügten Montagezettel der Firma HÄFELE.

Zusätzlich finden Sie auf dem Montagezettel folgende Abbildungen und Montagehilfen:

- Montage der Abdeckkappe 13
- Einstellen der Schubkastenblende
- Aushängen des Schubkastens
- Abnehmen der Schubkastenblende

5

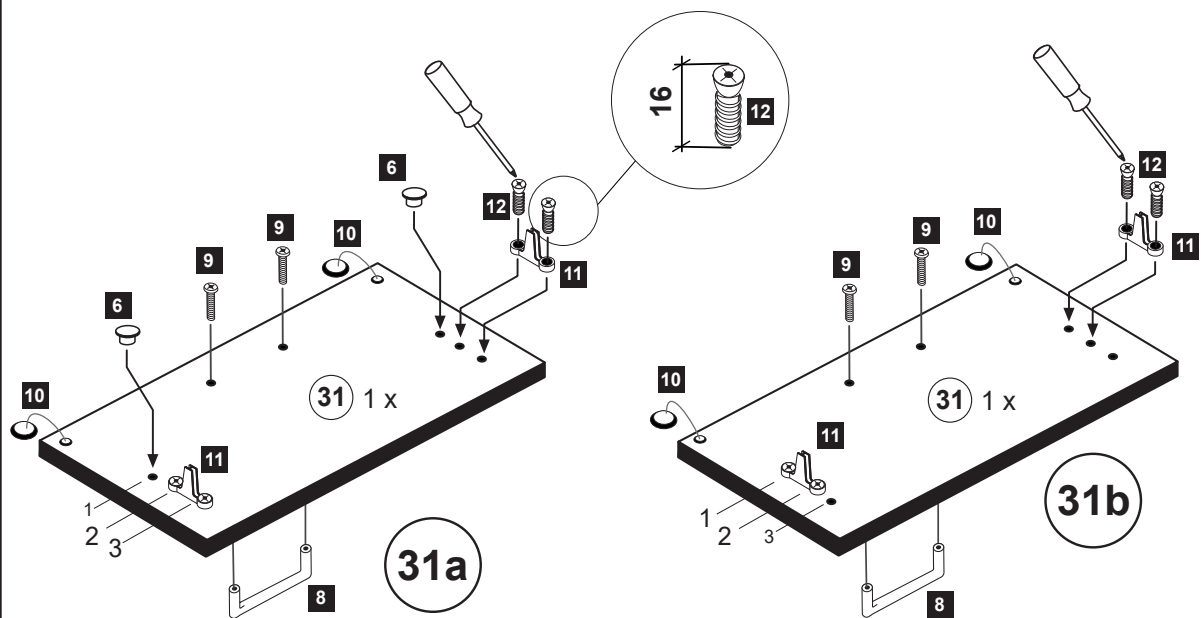
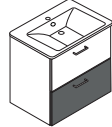
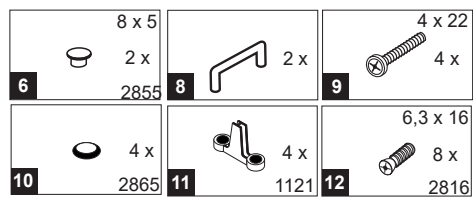

9

5,8 x 55	8 x 30
2 x	2 x
13 2840	14 2842

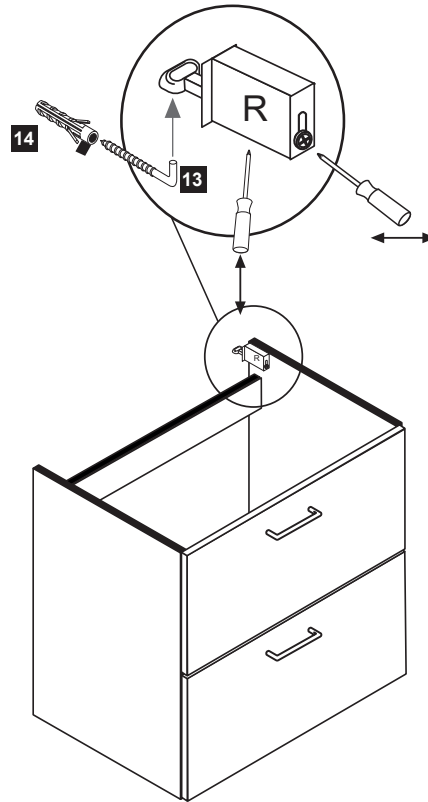

10

Silikon 25ml	1 x
21 1970	

Waschbeckenmontage

1. Silikon auf Stirnkante der Seiten auftragen
2. Waschbecken auflegen
3. Fuge zwischen Waschbecken und Wand mit Silikon abdichten
4. Seitliche Fugen zwischen Waschbecken und Unterschrank mit Silikon abdichten

